

COMFORTABLE WORKPLACE

The GIANT wheel loader is equipped with ROPS / FOPS safety roof, air suspended seat with armrests, adjustable steering column, safety doors, adjustable dashboard, vibration-damped workplace.

Also available with:

Safetyroof Deluxe: 2 working lights, 2 rear working lights, window in the front and window rear with wipers and 2 mirrors.

Cabin: enclosed cab with heating and ventilation, radio mp3 player, insulation package, 2 working lights front, 2 rear working lights, mirrors, front and rear wiper.



TYRE CHOICE



12.0/75-18 TR11 (94x30 cm)	15/55x17 AS (85x39 cm)	19/45x17 AS (86x49 cm)	500/40x17.5 Flota 3 (88x50 cm)	445/45x19.5 Kargo (94x45 cm)	500/45x20 AS (98x48 cm)
140 cm machine width	152 cm machine width	162 cm machine width	165 cm machine width	165 cm machine width	165 cm machine width

WHEEL LOADERS

GIANT wheel loaders are totally designed and produced in own management in Oisterwijk (the Netherlands). In 2009 TOBROCO Machines has started with the development for new models for the existing range. These new models will replace the existing ones. For development TOBROCO Machines is using a sophisticated 3-dimensional design program. Thus before taken a machine in production, it's performance can be tested already. During the development of the new models TOBROCO takes care of the demands and needs of their customers. TOBROCO is a specialist in compact wheel loaders. In the modern plant in Holland they build the GIANT wheel loaders. We work with the best suppliers: Kubota, Rexroth. GIANT is robust, durable and quality made in Holland!

Also TOBROCO Machines offers you a very big variety of implements. The majority of these implements is designed and produced by TOBROCO Machines, and because of this, the implements are optimally adapted for your GIANT, which is more efficient this way.



GIANT made in Holland



TOBROCO

Industrielaan 2
5061 KC Oisterwijk
Tel.: +31 (0)13-5211212
Fax: +31 (0)13-5234045
Internet: www.tobroco.com
E-Mail: info@tobroco.com



GIANT

Team TOBROCO

Industrielaan 2, 5061 KC Oisterwijk
Tel.: +31 (0)13-5211212
Fax: +31 (0)13-5234045
Internet: www.tobroco.com
E-Mail: info@tobroco.com

V5003 TELE
V6004T TELE



TELEHANDLERS

Flexible, strong and comfortable jack of all trades



WHEEL LOADERS

To full fill the needs and demands of her customers TOBROCO offers a wide range of wheel loaders. This range consists out of 25 different types of loaders with a service weight between 1000 kg and 4150 kg. In this leaflet, we will show you our special V6004T TELE. This machine is characterized by the telescopic lifting arm. For further information about other types and implements we refer to our other leaflets or our website (www.tobroco.com).

QUALITY

The heart of the machine has top class components Kubota diesel engine, Bosch Rexroth hydraulic pumps, heavy drive shaft line, Comer planetary axles, heavy duty 14 ton with 100% electr. differentiallock, construction and assembly in the Dutch Oisterwijk ensure that the GIANT wheel loaders economical clean and super reliable.



TECHNICAL DATA

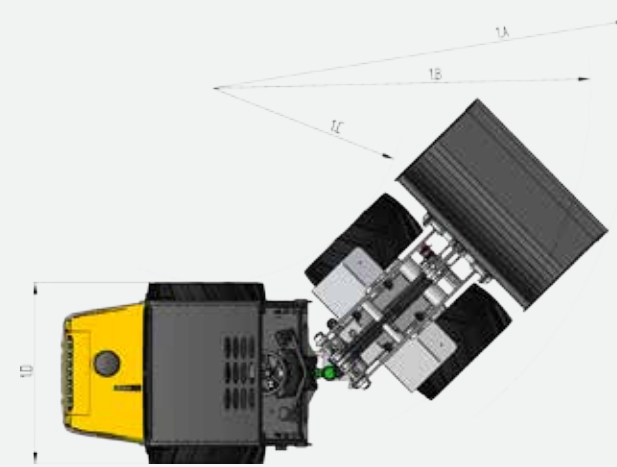

	V5003 TELE	V6004T TELE	
A	Wheelbase	1971	1971
B	Total length	4057	4057
C	Length with bucket	4818	4818
G	Seat height	1300	1345
H	Max. height with ROPS/FOPS roof	2273	2318
I	Max. height with cabin	2265	2310
J	Height front frame	1685	1730
K	Max dump height	2418 / 3043	2463 / 3088
L	Max. height bucket pin	3320 / 4253	3365 / 4298
M	Height with bucket	4341 / 4878	3990 / 4923
N	Roll back angle ground level	41°	41°
O	Roll back angle	47°	47°
P	Max dump angle	40°	40°
Q	Max. drive angle	27°	30°
R	Diameter standard tyre	850	940
1A	Maximum radius	3281	3281
1B	Outer turning radius	2859	2859
1C	Inner turningradius	1476	1476
1D	Width	1340	1400

Sizes in mm, on standard tyres.

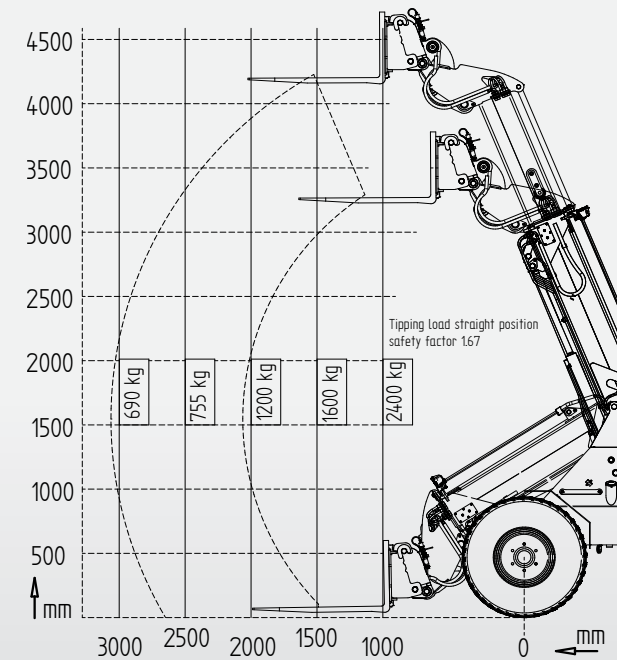

	V5003 TELE	V6004T TELE
Engine	4 cyl. Kubota Turbo 50 HP / 36 kW	4 cyl. Kubota Turbo 60 HP / 44 kW
Service weight*	3750 kg	3850 kg
Driving hydraulics	Hydrostatic automotiv	Hydrostatic automotiv
Driving speed	0-10 km/h / 0-25 km/h	0-10 km/h / 0-28 km/h
Driveline	Planetary axles 12 ton	Planetary axles 14 ton
Diff. lock	Electr.-hydraulic engagement 100%	Electr.-hydraulic engagement 100%
Standard tyres	11,5/80x15,3 AS (134 cm machine width)	12,0/75x18 TR-11 (140 cm machine width)
Brake	Hydraulic	Hydraulic
Parkingbrake	Drum brake	Drum brake
Attachment bracket	GIANT Standard Hydraulic	GIANT Standard Hydraulic
Working hydraulics	70 L/min (220 bar)	67,5 L/min (220 bar)
Lifting capacity	2000 kg	2000 kg
Tipping load straight	1000 kg / 2000 kg extended / retracted	1000 kg / 2000 kg extended / retracted

MADE IN HOLLAND

The GIANT wheel loaders build according to the modern lean-manufacturing process in the new factory in Oisterwijk (Netherlands). The machines find their way to satisfied end-users across Europe.

WORKING HEIGHT

With a lifting height of 4.25 meters, the TELE machines easily be used for all loading and unloading activities.

TIPPINGLOAD

With the mast lowered the tippingload is 2000 kg on the forks, with the mast retracted the tipping load is 1000 kg on the palletforks.



● V5003 TELE 50 HP / 35 kW

Modern Kubota dieselengine, Bosch Rexroth hydraulics, Heavy 12 tons planetary drive-line with highspeed, 0-25 km/h, 100% electric sper differential.



● V6004T TELE 60 HP / 44 kW

Modern Kubota dieselengine, Bosch Rexroth hydraulics, Heavy 14 tons planetary drive-line with highspeed, 0-28 km/h, 100% electric sper differential.

